

REVISION RECORD				
SYM	DESCRIPTION	BY	DATE	APPD

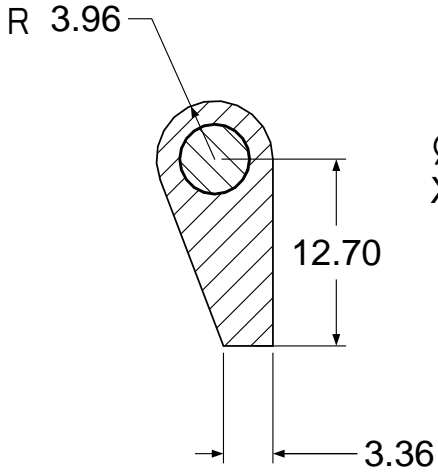

Ø 3.26
X 2

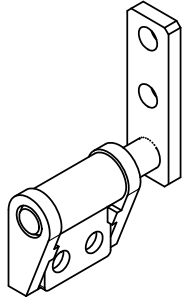
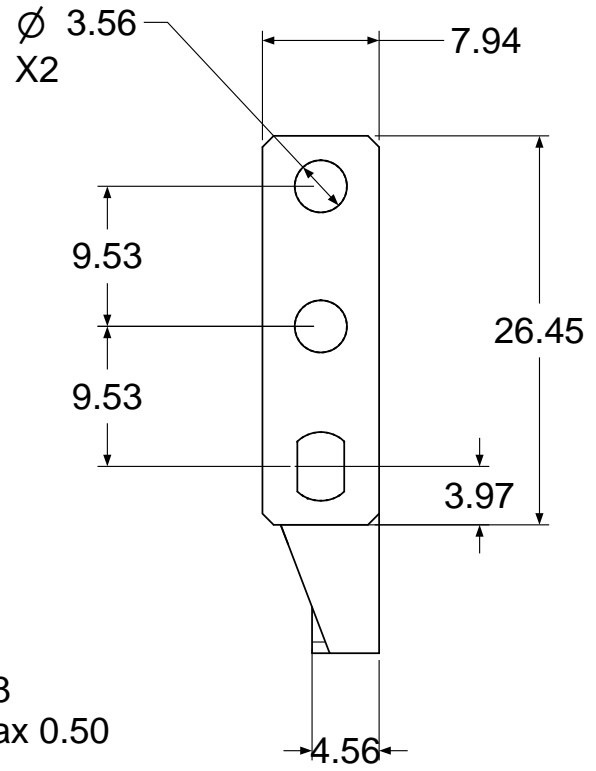
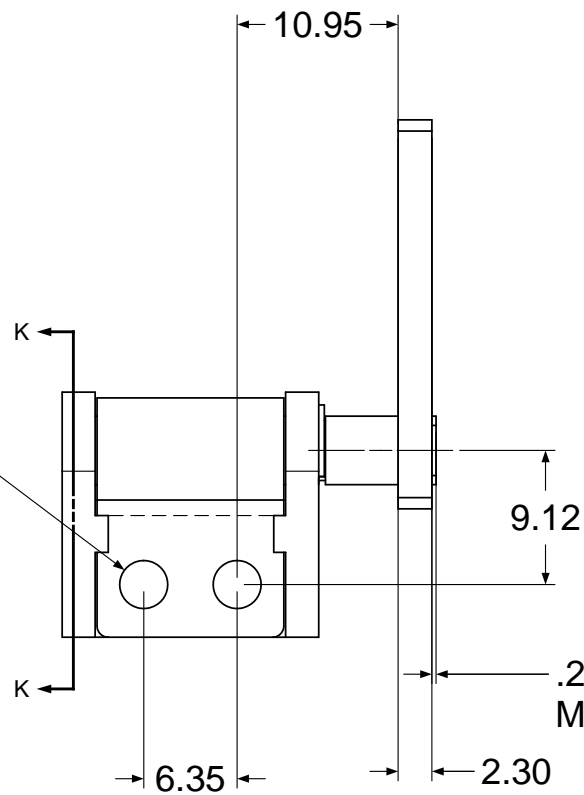

NOTES:
 Rt CCW TORQUE = 10 Kg-cm +/- 15%
 Rt CW TORQUE = Less than ccw
 Lt CW TORQUE = 10 kg-cm +/- 15%
 Lt CCW TORQUE = Less than cw

USED ON	SOLID	REV	TOLERANCES		ENGLISH / METRIC Shineplot Enterprise			
			ENGLISH	METRIC				
NEXT ASSY			.XX .0015 IN	.X ±.3 MM	DRAWN BY	DATE	MATERIAL	
			.XXX .0005 IN	.XX ±.13 MM			TITLE	
QUANTITY			.XXXX .0002 IN	.XXX ±.05 MM			A-401-C1	
PER ASSY, PCS	1		ANGLES 7.57		CHECKED BY	DATE	SIZE	REV
TOTAL, PCS	1		SURFACE 63				C	0.0
					SCALE 1:1		SHEET 1 OF 1	